

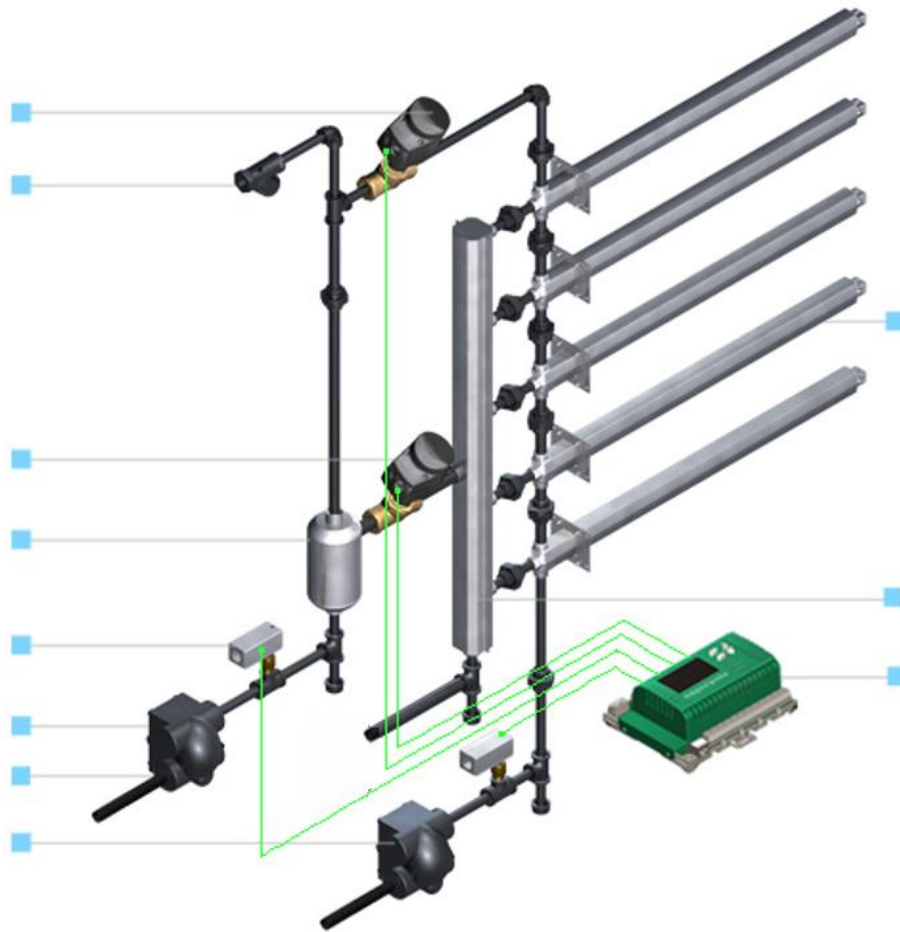

**neptronic®**

# Pressurized Condensate Return System (PCR)

For use with SKD-J Direct Steam Injection Humidifiers



Installation Instructions and User Manual

**READ AND SAVE THESE INSTRUCTIONS**



## Foreword and Safety Instructions

### Neptronic Company Overview

Founded in 1976, we're a private corporation that designs, manufactures and distributes products for the HVAC industry. Our product line includes intelligent controllers, electronic actuators, actuated valves, humidifiers and electric heaters.

Our products are designed and manufactured by over 250 dedicated employees in our 7,500 m<sup>2</sup> (80,000 ft<sup>2</sup>) state-of-the-art facility located in Montreal, Canada. Using a vertical integration model, our entire manufacturing chain is under one roof from software and hardware development, to SMT circuit board assembly, to sheet metal fabrication, to product testing ensuring that our products are engineered to last.

We currently hold several national and international patents and with our continued commitment to research and development, we provide innovative products and technologies for the ever-evolving challenges of the HVAC industry. Exporting over 70% of our sales, we have an exclusive distribution network around the globe that provides comprehensive solutions to our worldwide customers.

### About the Manual

These installation and operation instructions have been developed to facilitate the installation of the Pressurized Condensate Return System.

- The strict application of these instructions will ensure the conformity of your installation and operation as per the manufacturer's recommendations.
- The application of these instructions is one of the conditions for the application of the warranty.
- The application of these instructions does not ensure, at any time conformity to procedures, regulation or local codes, regarding electric installation and connection to local water supply.

2022©: All rights reserved. This document cannot be reproduced totally or partially by any means whether, electronic, mechanical, photocopy, recording or other, without prior written authorization of Neptronic.

### Electricity



All work concerned with electrical installation **MUST** only be performed by skilled and qualified technical personnel such as an electrician or a technician with appropriate training). The customer is always responsible for ensuring the suitability of the technical personnel.

Please observe the local regulations concerning the provision of electrical installations.

### Correct Use

Neptronic systems and its products are designed only for humidification use. Any other application is not considered appropriate for the intended purpose. The manufacturer cannot be made liable for any damage resulting from incorrect use.

### General Warranty

This product is subject to the terms and conditions described at <http://www.neptronic.com/Sales-Conditions.aspx>.



# Contents

Overview..... 3

    Product Description..... 3

    Principle of Operation..... 4

    Handling and Lifting..... 5

    Unpacking ..... 5

    Specifications ..... 5

        Dimensions..... 5

        PCR Capacity ..... 6

Installation Overview..... 7

    Installation Method Statement ..... 7

        Step 1 – Install SKD Humidifier..... 8

        Step 2 – Secure PCR Tank..... 10

        Step 3 – Connect PCR Tank to Drain Port..... 11

        Step 4 – Install the Steam Relief Valve ..... 11

        Step 5 – Install the Steam Supply Valve ..... 12

        Step 6 – Connect PCR tank to Condensate Return ..... 13

        Step 7 – Strainer Installation..... 14

    Electronic Steam Controller (SKDESC) ..... 15

        Technical Specifications ..... 15

        Wiring ..... 16

        Symbols Used in this Manual..... 17

        Controls Menu (637)..... 17

        Alarms and Notifications ..... 26

        Operating Menu Display ..... 28

Initial Verification..... 29

Start-Up Procedure..... 30



## Overview

---

### Product Description

The objective of the Neptronic patent-pending pressurized condensate return (PCR) system is to return condensate generated within the steam dispersion tubes of a direct steam humidifier back to the boiler for the following reasons:

- Eliminate the need for a drain
- Reuse condensate and avoid waste
- Increase energy efficiency

By design, the PCR system eliminates the need for a heat exchanger and therefore all inspections and de-scaling work are simply unnecessary. In fact, there is no need for a maintenance regimen since the PCR is just an empty vessel.

With the PCR system, no maintenance means no downtime. All critical components of the PCR system are externally located, easily accessible and all critical functions of the PCR system are monitored and controlled in real-time by the independent PCR Electronic Controller. The controller can be stand-alone or easily integrated to a Building Automation System via BACnet MS/TP or Modbus.

*Jacketed Tube Steam Distribution.* The steam dispersion tubes are made with stainless steel (1 3/8"). The jacketed tube steam distribution consists of multiple horizontal tubes on a common vertical header. Upon a demand for humidity, the SKDESC-J controller opens the isolating valve to preheat the outer jacket. This prevents any condensate from forming in the inner tube that could wet the duct or AHU floor when steam is flowing through the tubes' nozzles. When the jacket reaches its operating temperature, the ESC controller slowly opens the steam modulating valve feeding steam directly into the inner tube(s). The steam escapes the tube(s) through multiple calibrated nozzles and mixes with the airflow to maintain the desired humidity level.

The following configurations are available with the jacketed tube steam distribution:

- Multi-Tube
- Mini Rack

Each configuration suits a specific requirement and provides the following advantages:

- Low, medium, and high capacity applications
- Average and short non-wetting distances

Duct, AHU, and limited space installations

#### **PCR Means Maintenance Free**

- Real-time status and monitoring.
- No systematic verification required.
- No de-scaling required.
- No downtime.
- No flooding of header.

This innovative, patent-pending Neptronic technology is developed to simplify installation, provide maintenance-free and energy-efficient operation, and to enable monitoring of the system for direct steam applications.



## Principle of Operation

- The header has a drain port (1), at the bottom to evacuate the condensate that could occur, which then flows into the PCR tank (2).
- When the tank level setpoint is attained, the ESC controller opens the Steam supply valve (3) to empty the PCR tank (2) into the Condensate return (5) system.
- The check valve (4) prevents steam pressure from reversing into the header.
- The ESC controller continues to monitor the tank's condensate level and temperature.
- When the PCR tank (2) is empty, the ESC controller closes the Steam supply valve (3) and opens the Relief valve (6) to partially relieve pressure in the PCR tank (2) and allow the flow of condensate from the header to the PCR tank (2).
- With the Relief valve (6) open, the check valve (7) prevents backflow from the Condensate return (5) to the PCR tank (2).

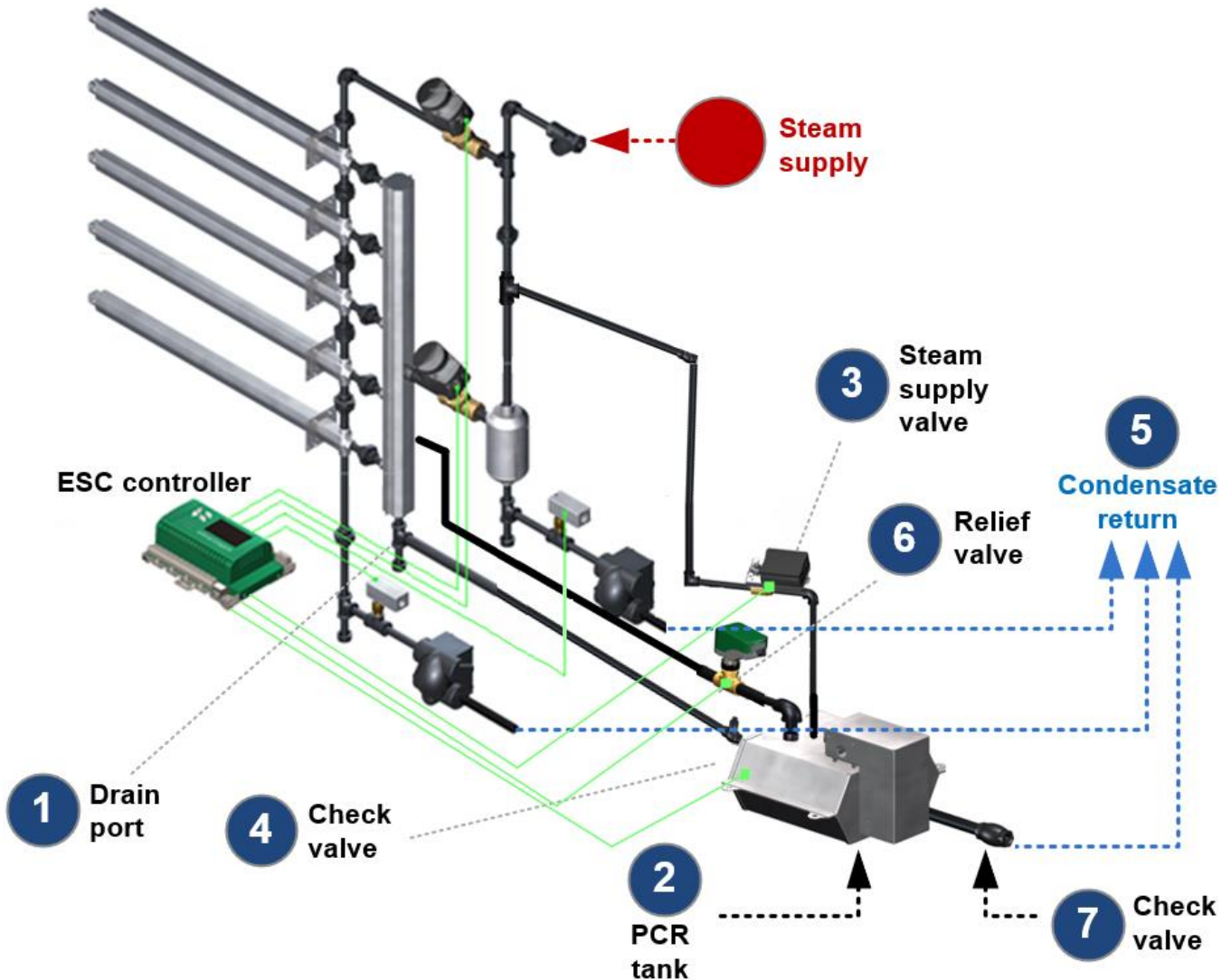

Illustration 1 – Principle of Operation



## Handling and Lifting



The Pressurized Condensate Return System **MUST** always be handled and lifted with care and must remain in its original packaging for as long as possible prior to installation.

## Unpacking

The Pressurized Condensate Return System is shipped inside carton boxes or in a wooden crate. Remove packing and skids prior to commissioning.

## Specifications

The following equipment is included with the Pressurized Condensate Return System.

<b>PCR tank</b>	Material:	304 stainless steel
	Ports	4 NPT 1/2" (DN15) ports for condensate inlet, condensate outlet, steam supply and steam relief
	Mounting holes	4 mounting holes with diameter of 3/8" (10mm)
<b>Check valves</b>	Condensate inlet	Swing check valve with open delta P of 0.5 PSI (3.5 kPa), NPT 1/2" (DN15)
	Condensate outlet	Spring inline check valve with open delta P of 2 PSI (13.8 kPa), NPT 1/2" (DN15)
<b>Actuated valves</b>	Steam supply	Neptronic BM000F actuator with ball valve
	Steam relief	Neptronic VT000 linear actuator with zone valve

## Dimensions

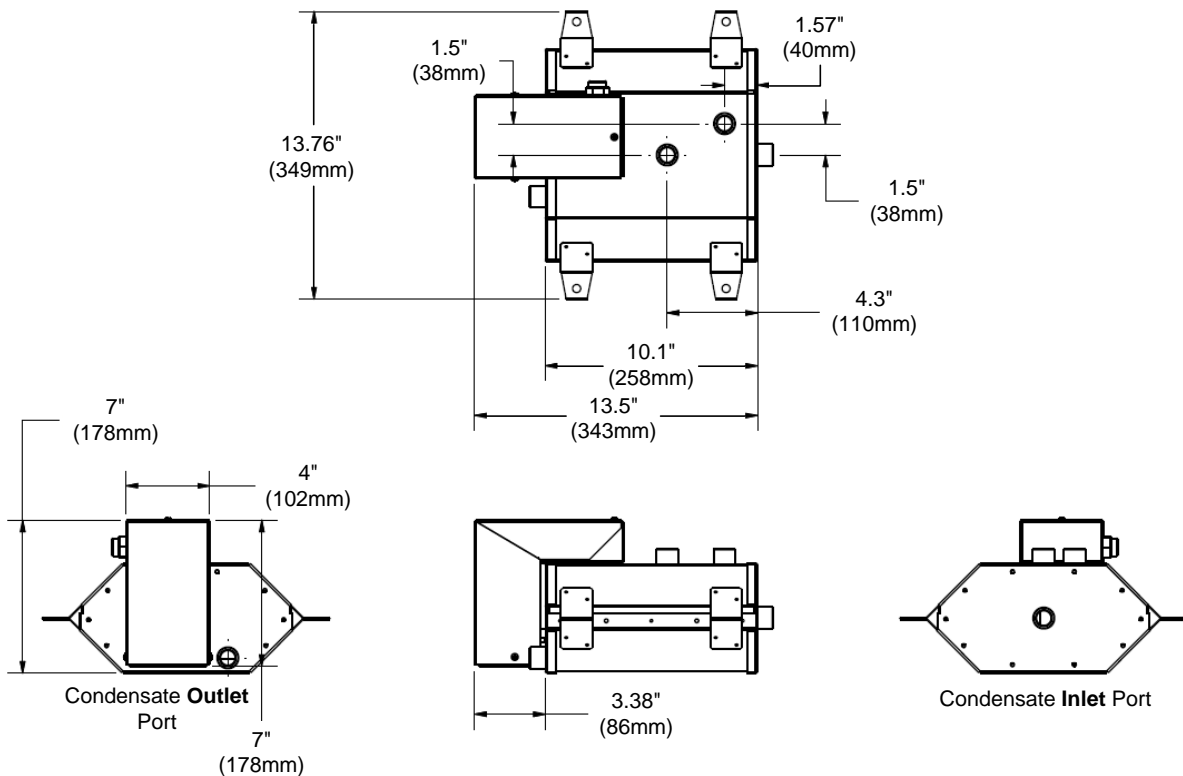

Illustration 2 – PCR50 Dimensions



## PCR Capacity

The PCR capacity is obtained based on the system differential pressure ( $\Delta P$ ), which is defined as:

$$\Delta P = P_{Supply} - P_{recovery}$$

**P<sub>supply</sub>**: Steam supply pressure to the humidifier.

Steam supply pressure may decrease after opening steam supply valve. Size piping and pressure relief valve accordingly.



*Important: Ensure that the steam supply pressure does not exceed 15 psi (103 kPa).*

**P<sub>recovery</sub>**: Pressure from condensate recovery system.

For vented systems, this pressure is equivalent to 1 psi (7 kPa) for every 27" (686mm) of condensate rise. It is not recommended to connect the PCR and steam trap outlets together. Additional design considerations must be taken into account for pressurized returns.

Once the system differential pressure ( $\Delta P$ ) is obtained, the PCR capacity can be obtained using the following table:

$\Delta P$ (psi) [kPa]	Condensate Capacity (lb/hr) [kg/hr]
6 to 14 [41 to 97]	100 [45]
5 [34]	90 [41]
4 [28]	75 [34]



*Important: It is not recommended to connect the PCR system to the condensate return line if the differential pressure ( $\Delta P$ ) is below 4 psi (28 kPa).*





# Installation Overview



All installation work must comply with local regulations.

All work related to the installation of the Pressurized Condensate Return System MUST only be performed by skilled and qualified technical personnel such as plumbers or technicians with appropriate training. The customer is responsible for ensuring their suitability.

For the installation of the Pressurized Condensate Return System and associated components, there are no specific tooling requirements.

## Installation Method Statement

- Step 1 – Install Steam Jacketed Distributor
- Step 2 – Steam Header Installation
- Step 3 – Secure PCR Tank
- Step 4 – Connect PCR Tank to Drain Port
- Step 5 – Install Steam Relief Valve (VT000)
- Step 6 – Install Steam Supply Valve (BM000F)
- Step 7 – Connect PCR Tank to Condensate Return
- Step 8 – Strainer Installation

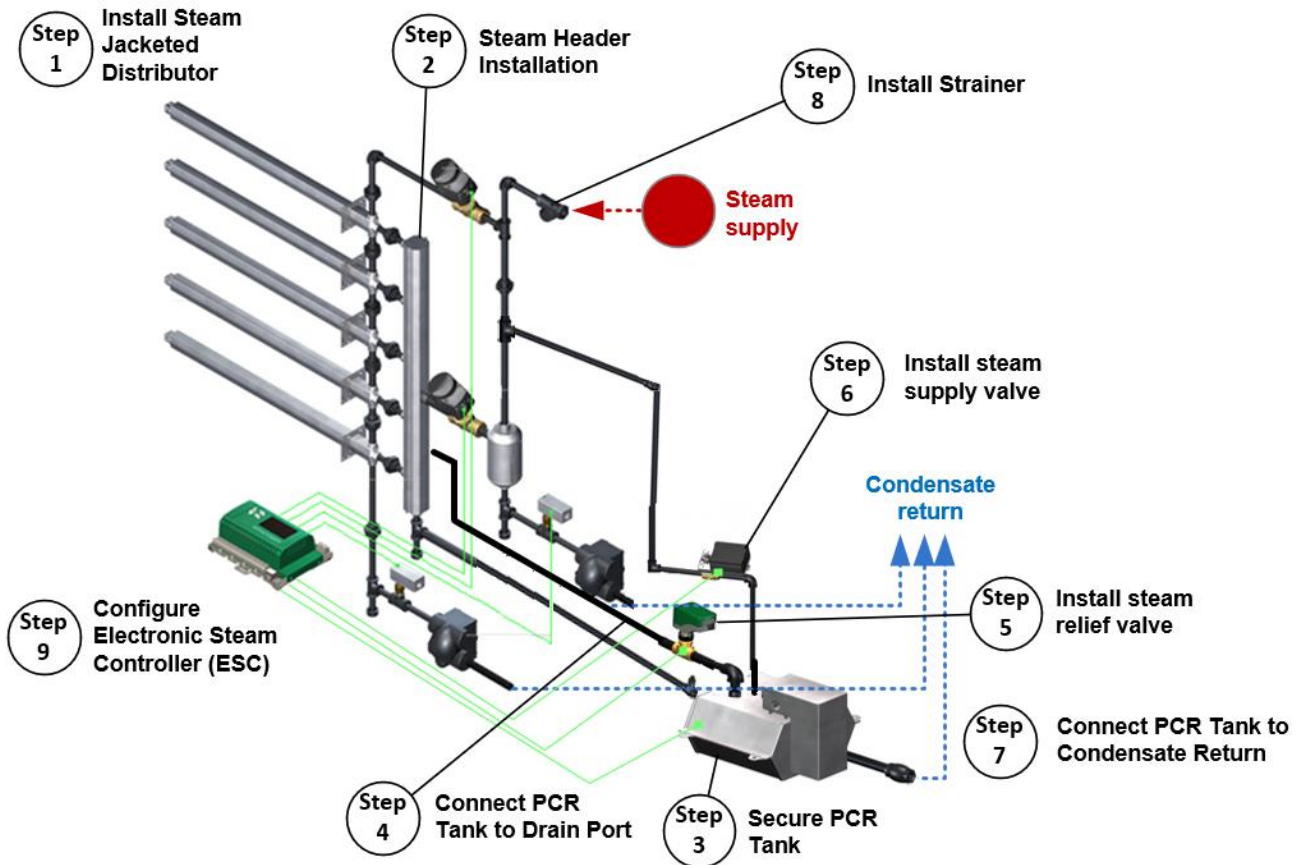

Illustration 3 – Installation Steps Overview





## Step 1 – Steam Jacketed Distributor Installation

### General Considerations



**Any installation work must be carried out by suitably qualified personnel.**

Consider the following points before deciding the location for the Direct Steam Injection Humidifier steam distribution system:

- Plan a location that is easy to access and permits an easy inspection and servicing of the humidifier.
- Do not install the humidifier where failure of the appliance could cause damage to the building structure or to other expensive equipment.
- Verify that the construction of the duct or AHU wall is suitable to support the steam distributors throughout the duration of the installation life.

### Positioning the Steam Distributors

- The steam distributors must be installed to ensure that the visible steam trail is kept to the shortest possible length.
- Steam nozzles must face the airflow to minimize the absorption and non-wetting distance.
- Locate the steam distributors far enough from elbow or fan to be in laminar air flow to ensure proper evaporation distance.
- There must be sufficient straight duct downstream from the steam distributors for absorption of the steam.

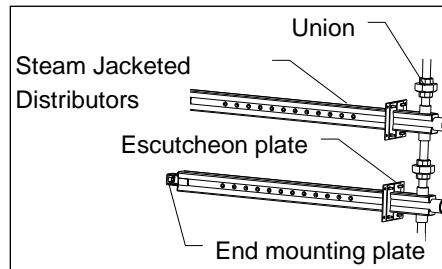

Illustration 4 - Manifold Installation

- Position the steam distributors so that the distance between them is the same. Use proper size unions to connect the jacket of each steam distributor together.
- For Mini Rack models, position the system evenly so that the spacing between the top distributors and the duct/AHU is the same as the bottom distributors and the duct/AHU.
- Use metal screws to mount the escutcheon plate to the wall of the duct or AHU.
- Secure the end of the steam distributor with 3/8" (10mm) rods either vertically or horizontally.

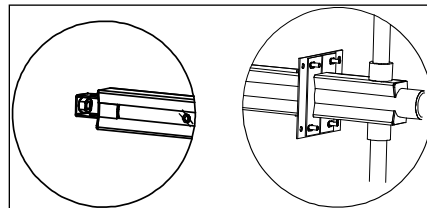

Illustration 5 - End Mounting Bracket and Escutcheon Plate



## Step 2 – Steam Header Installation



Any installation work must be carried out by suitably qualified personnel.

### Steam Header Installation

- Align the outlets of the steam header with the steam inlet of each steam distributor.
- For Multi-Tube, use proper size union to connect the steam header to the steam distributors. Refer to Illustration 6 – Steam Header with Union. The distance between the header and the steam distributor’s inlet port must not exceed 8” (203 mm) and both header and steam distributor ports must be aligned, no elbows can be used to pipe the connection.
- For Mini Rack models, the connections between the steam header and the steam jacketed distributors are assembled at the factory. The steam distributors and the header assembly come as separate, single parts.

Install the PCR tank and related peripherals after the SKD humidifier's standard elements are installed. Please follow the supplied Jacketed Series instructions to install the:

- Steam distribution system
- Steam control valve
- Steam separator
- Temperature sensor
- Steam traps

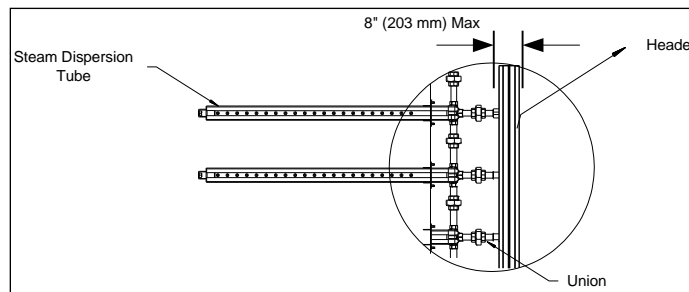

Illustration 6 - Steam Header with Union

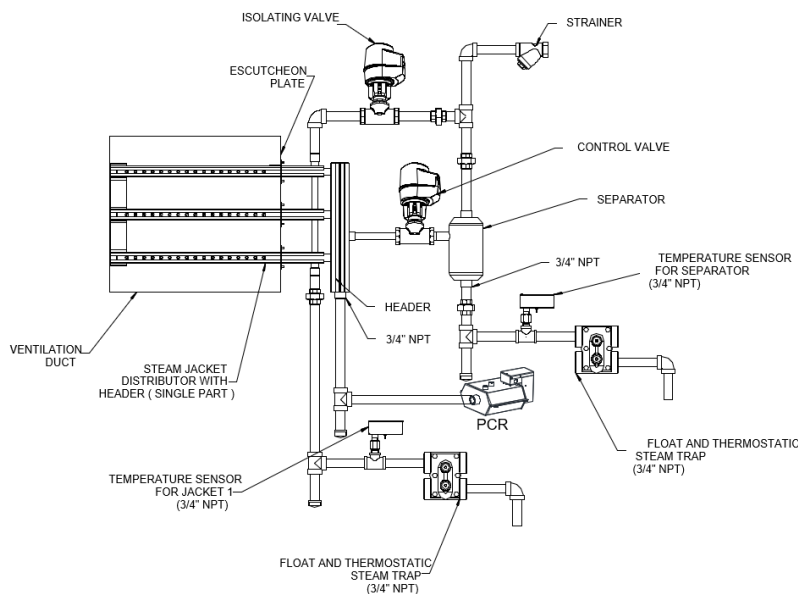

Illustration 7 - Mini Rack



### Step 3 – Secure PCR Tank

Select the location and secure the PCR tank to the ground using the four mounting holes on the mounting bracket under the PCR tank. Ensure that there is a distance of at least 6" (152mm) between the bottom of the header and the bottom of the PCR tank.

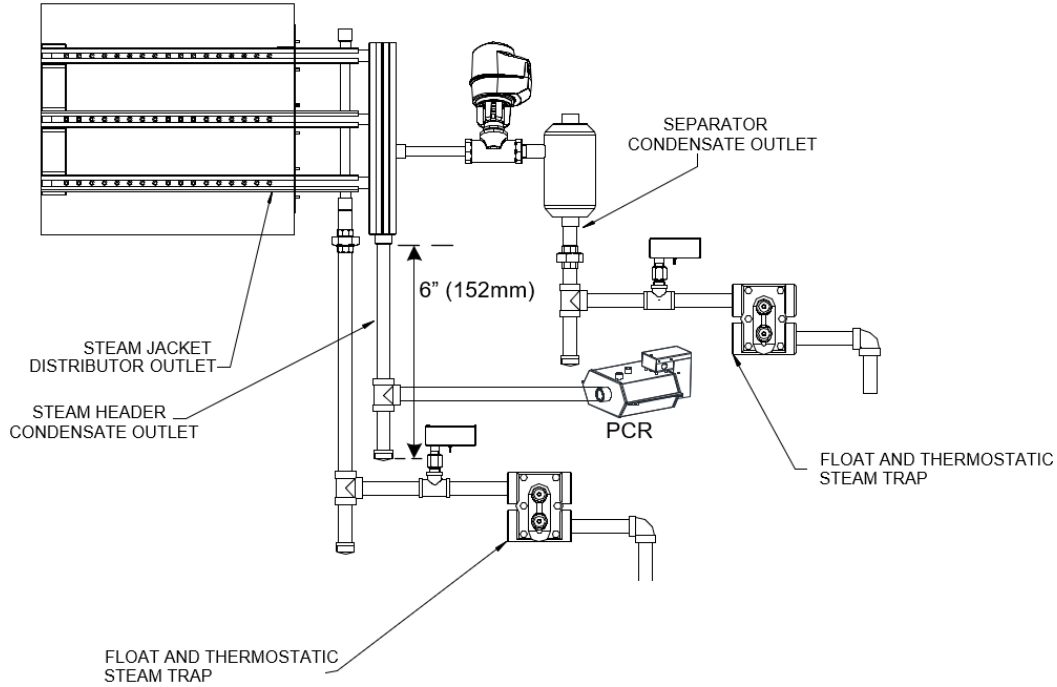

Illustration 8 – Distance Between PCR Tank and Header

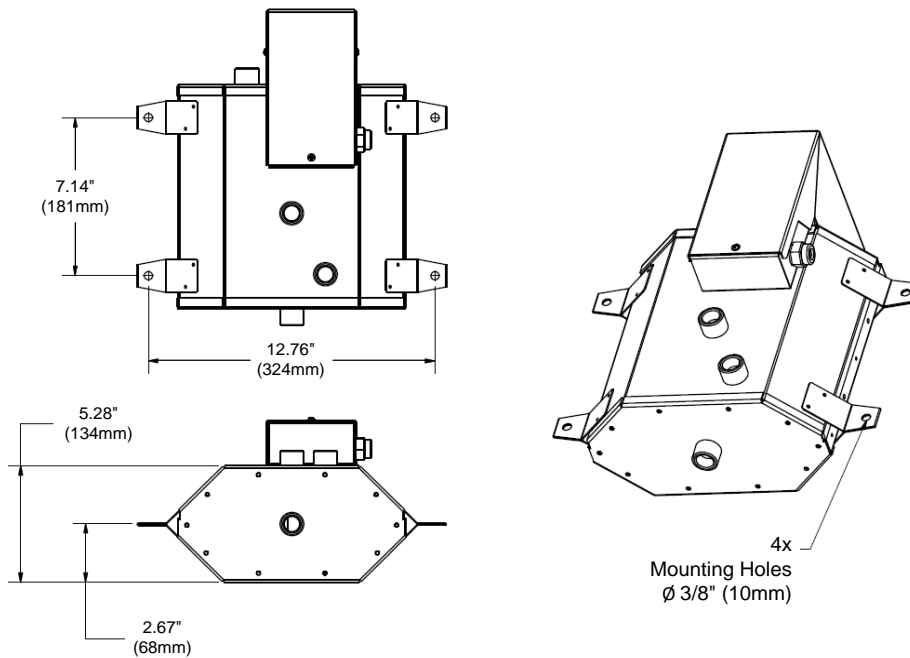

Illustration 9 – PCR Tank Mounting



### Step 4 – Connect PCR Tank to Drain Port

Connect the provided swing check valve to the condensate inlet port of the PCR tank. Orient the check valve vertically and levelled so that the head is pointing in the up direction. Connect the NPT 1/2" (DN15) piping between the PCR tank's inlet port and the steam distribution system's drain port. Ensure to respect the minimum distance between the bottom of the PCR tank and the top of the header as detailed in Step 3 – Secure PCR Tank on page 10.

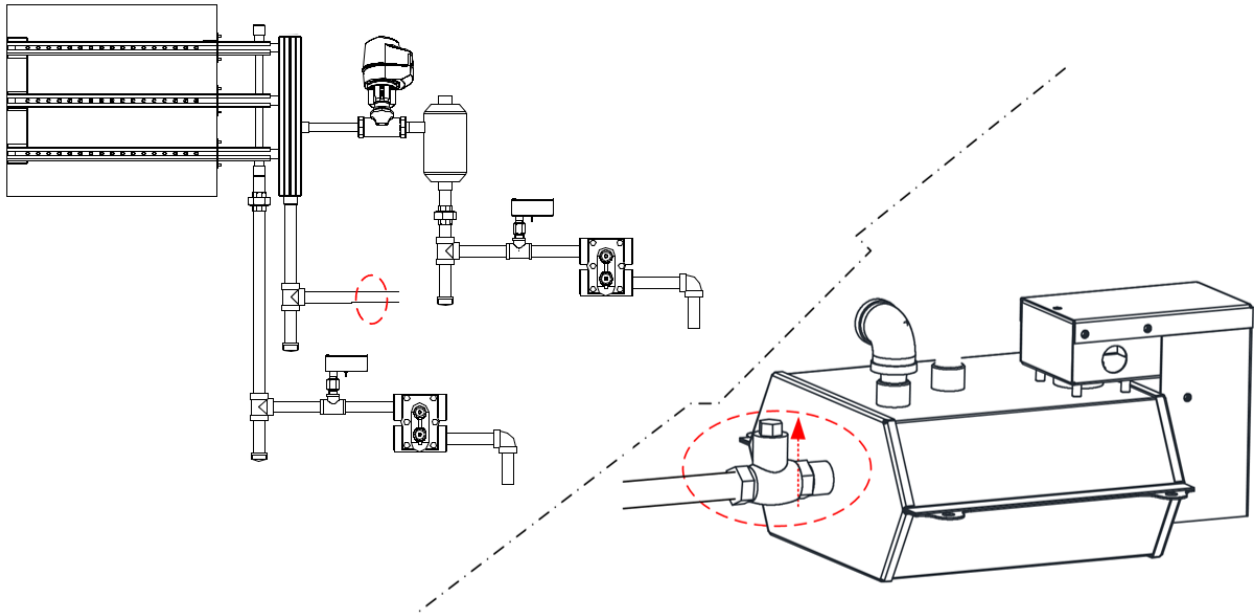

Illustration 10 – Connect PCR Tank to Drain Port

### Step 5 – Install the Steam Relief Valve

Install the provided steam relief valve (VT000 actuator with a normally open globe valve) between the relief valve ports of the header and the PCR tank as shown below. Set the "Rotation Direction" DIP switch to "Valve normally open".

#### 1) Rotation Direction

**OFF:** Valve is normally closed  
Red wire = Close (up)  
White wire = Open (down)

**ON:** Valve is normally open  
Red wire = Close (down)  
White wire = Open (up)

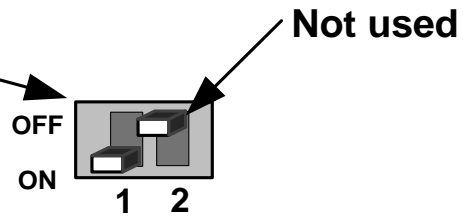

Illustration 11 – VT000 Actuator DIP Switch Settings

For more details concerning installation of the actuator and valve, please refer to the instruction manual provided with the product.



*Important: The valve must be installed as close as possible to the PCR tank on the horizontal piping line at a maximum of 8" (203mm) from the PCR tank.*

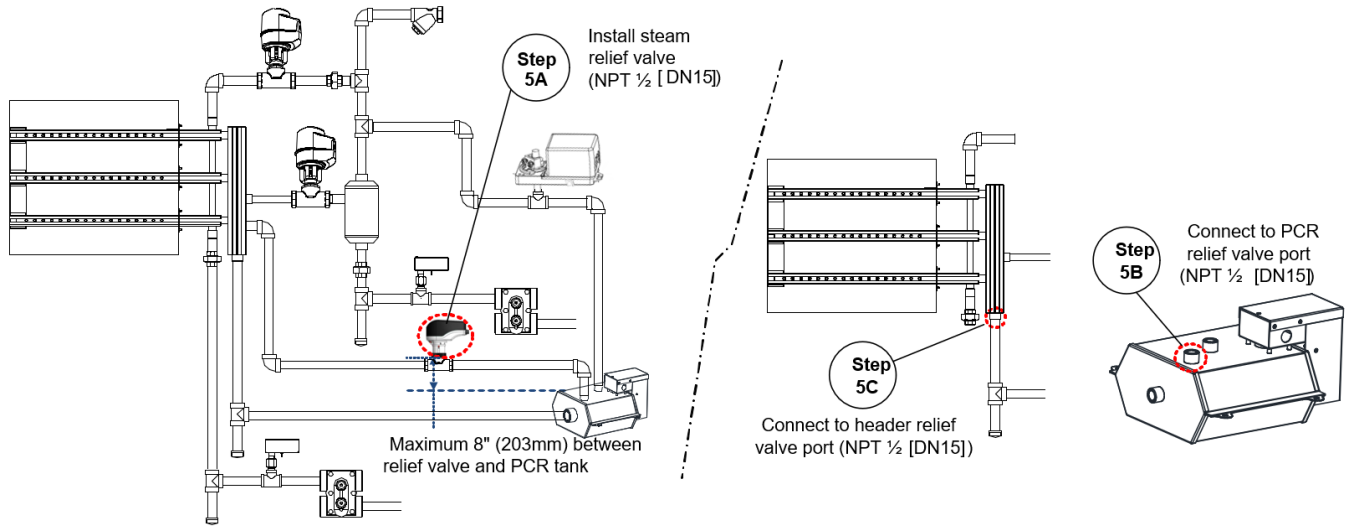

Illustration 12 – Steam Relief Valve Installation

### Step 6 – Install the Steam Supply Valve

Install the provided steam supply valve (BM000F actuator with an NPT 1/2" (DN15) ball valve) between the tee and the supply valve port of the PCR tank as shown below. Ensure the actuator is in the fail-safe close position. Set the DIP switches as follows:

- Rotation: CW
- Fail safe return at 0°
- PWM mode: 25 sec.

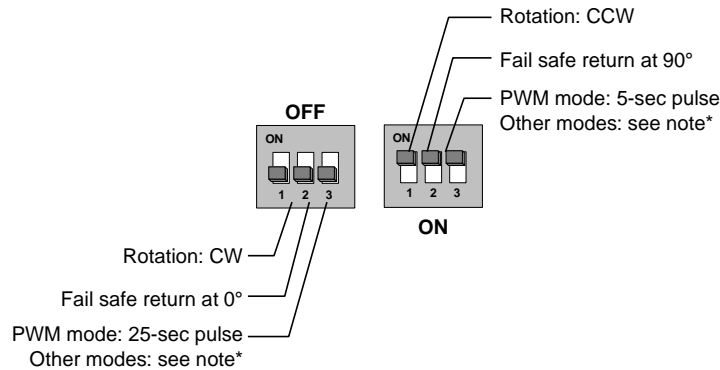

Illustration 13 – BM000F Actuator DIP Switch Settings

For more details concerning installation of the actuator and valve, please refer to the instruction manual provided with the product.



*Important: The valve must be installed at a maximum of 8" (203mm) downstream of the tee and a maximum of 8" (203mm) upstream of the steam separator. The valve must also be installed on the vertical line to avoid trapping condensate upstream of the valve.*



*Important: Ensure that the steam supply pressure does not exceed 15 psi (103 kPa).*



### Positioning the PCR Steam Control Valve

Install the actuated valve between 20 to 30 degrees from vertical in order to reduce the convection heat to the actuator.

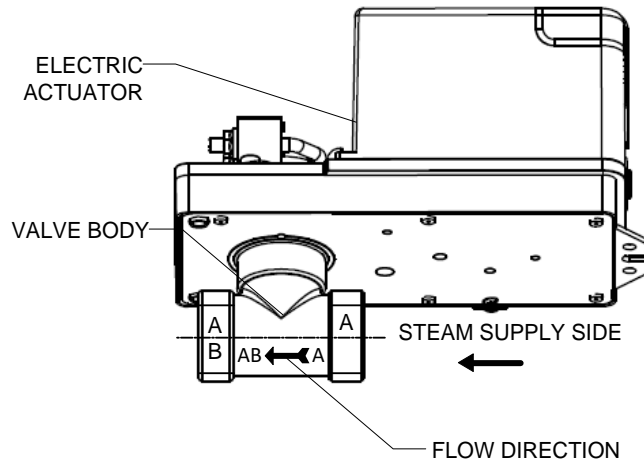

Illustration 14 – Flow Direction

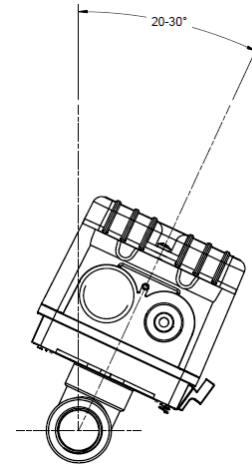

Illustration 15 – Tilt Angle

## Step 7 – Connect PCR tank to Condensate Return

Connect the provided spring inline check valve to the condensate outlet port of the PCR tank. Orient the check valve vertically and levelled so that the head is pointing in the up direction. Then connect the NPT 1/2" (DN15) piping between the PCR tank's outlet port and the condensate return line.

Connect spring inline check valve to the PCR tank's outlet port (NPT 1/2 [DN15])



Connect PCR tanks condensate outlet to condensate return line

Illustration 16 – PCR Condensate Return



### Step 8 – Strainer Installation

Install the strainer within six linear feet (1.83 linear meters) from the steam separator reducing the pipe length for the strainer and the first Pressurized Condensate Return System component.

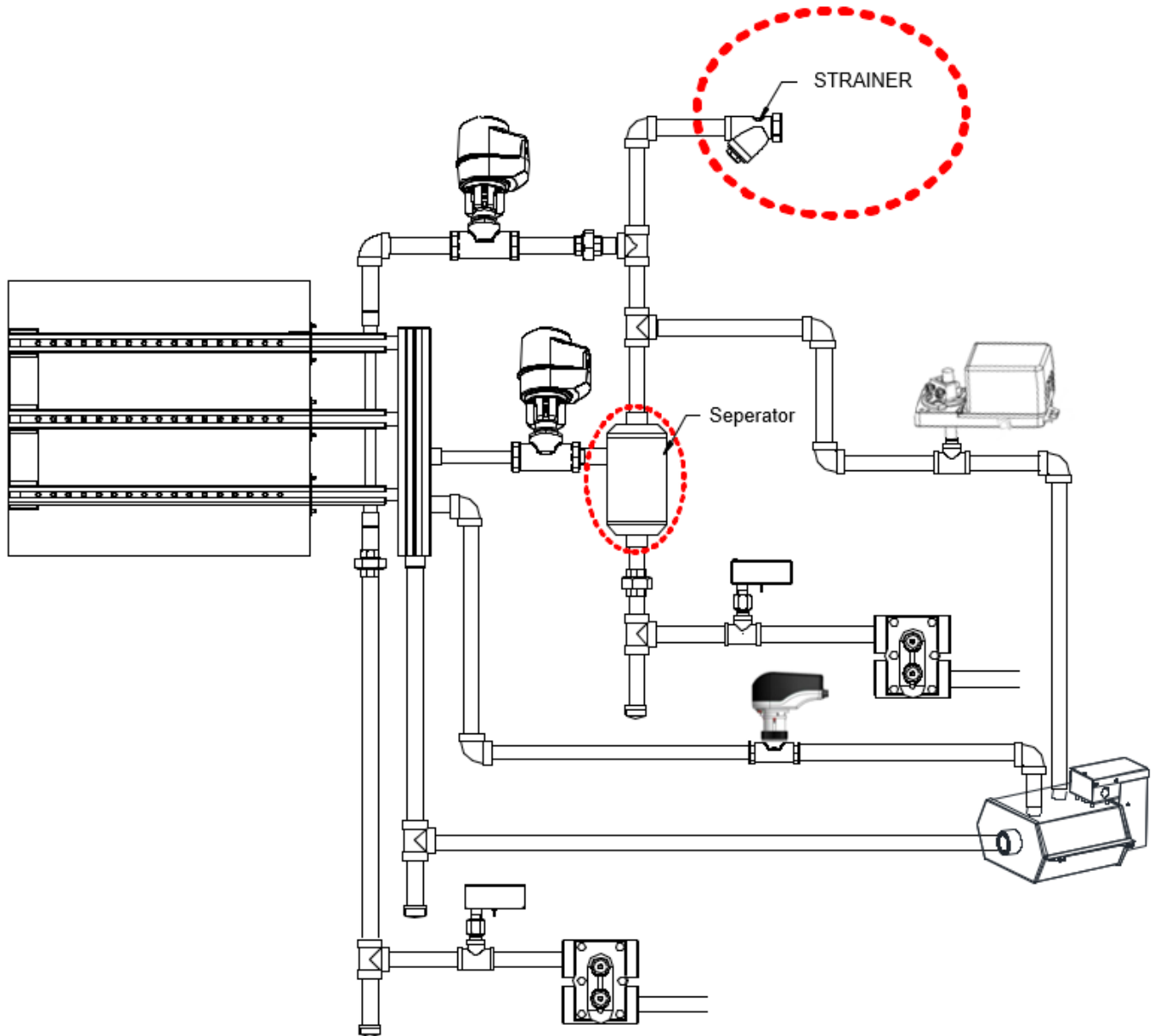

Illustration 17 – Strainer Installation





# Electronic Steam Controller (SKDESC)

## Models

**SKDESC-JP**

**SKDESC-JBP** with BACnet Communication

**SKDESC-JDP** with Modbus Communication

## Description

The Electronic Steam Controller SKDESC-J is made specifically for Neptronic SKD-J (Direct Steam Injection) Humidifiers.

## Features

- Conserves energy and eliminates condensate (dry operation)
  - Manages isolating and modulating valves
  - Pre-heats tube channel jackets only on demand for humidity
- Automatic temperature sensor adjustment
- On/Off or Modulating control
- Selectable internal or external control
- Configurable proportional control band & dead band
- Selectable Fahrenheit or Celsius scale
- BACnet or Modbus models available
- 24 Vac power supply (by others)
- Easy start up and troubleshooting
- Backlit LCD with simple icon and text driven menus



ESC Steam Controller Series

## Technical Specifications

Description	SKDESC-JP	SKDESC-JBP	SKDESC-JDP
Power Supply	24 Vac		
Power Consumption	50 VA		
Relay Output	2 relays		
Relay Rating	125 Vac, resistive load 10 amps		
Communication	-	BACnet	Modbus
Operating Temperature	32°F to 122°F (0°C to 50°C)		
Storage Temperature	-22°F to 122°F (-30°C to 50°C)		
Relative Humidity	5 to 95% non-condensing		
Weight	1.4 lb. (635 g)		
Dimensions A = 6.3"   160mm B = 5"   126mm C = 2.25"   57mm			

### Wiring

We strongly recommend that all Neptronic products be wired to a separate grounded transformer and that transformer shall service only Neptronic products. This precaution will prevent interference with, and/or possible damage to incompatible equipment.

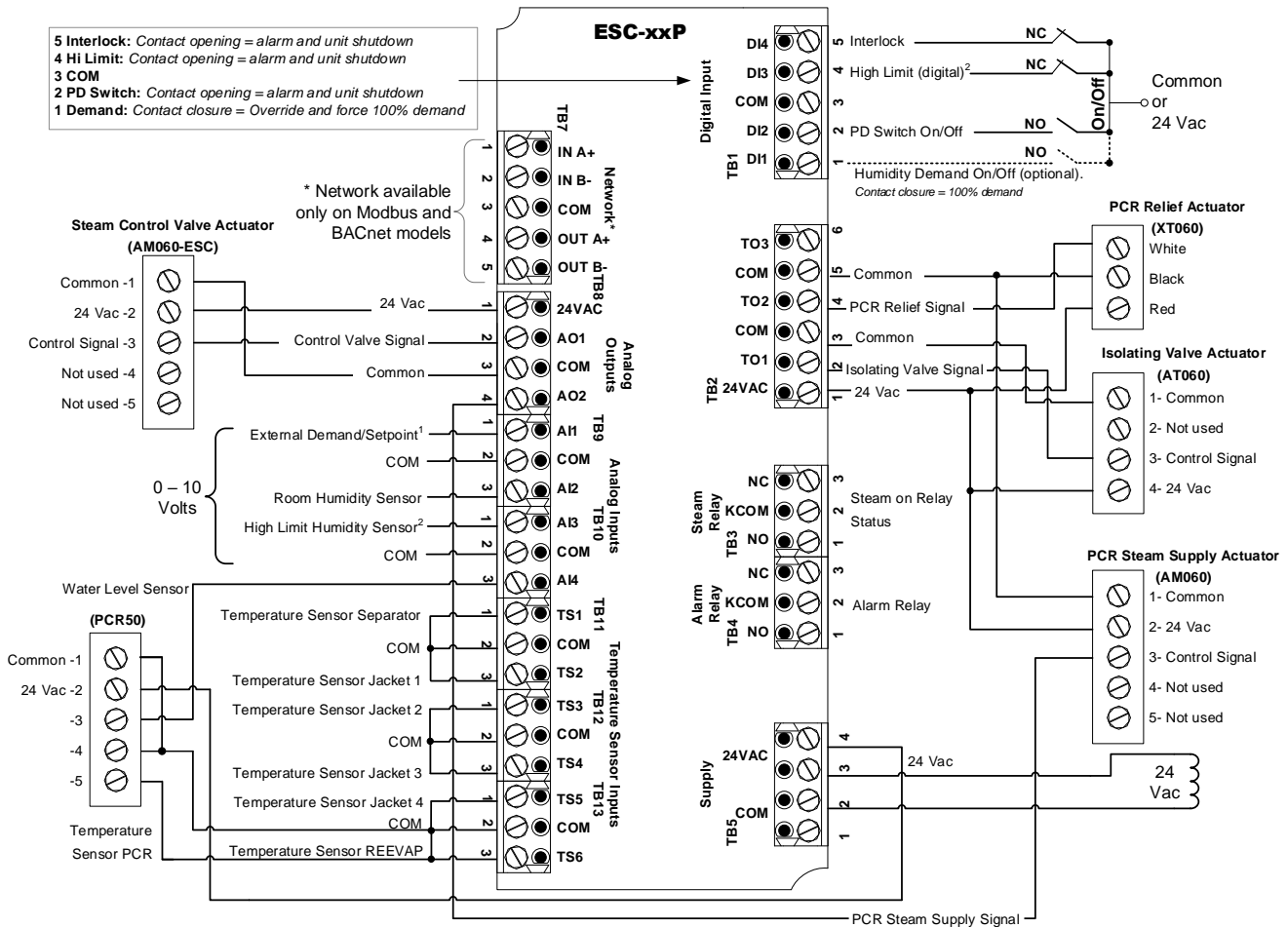

Temperature Sensor Jackets 1-2-3-4 sensor are optional, depending on system configuration.

Step	Description	Terminal Block	
Step 0, "Control Mode" = extern	Used for external control signal	TB9	Pin 1
Step 0 "Control Mode" = intern and Step 17, "External Humidity Setpnt" = on	Used for external setpoint signal		
Step 23, "High limit sensor" = digital	Used for connecting high limit sensor (Digital)	TB1	Pin 4
Step 23, "High limit sensor" = analog	Used for connecting high limit sensor (Analog)	TB10	Pin 1



### Symbols Used in this Manual

	Humidity
	Temperature
	Communication/Network
	Air Flow
	Timer/Clock

### Controls Menu (637)

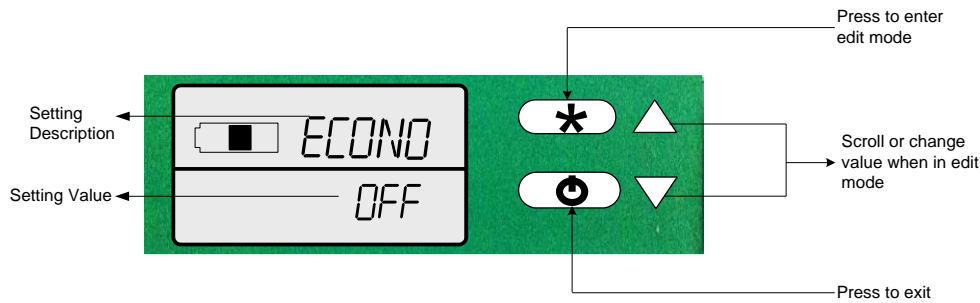

To enter the Programming Mode, perform the following steps:

1. Press to start and enter password (see Step 1 “enter passwr”).
2. Use the arrows buttons or to navigate the menu.
3. Press to enter edit mode of the displayed value.
4. Once in edit mode, use the arrows buttons or to change values. Changed values are automatically saved.
5. Press to exit edit mode of the displayed value.
6. Return to step 2 or press to exit the mode. Auto exits if no actions are taken after 5 minutes.



1. "ENTER PASSWORD"



Value: 637

Enter the password within 1 minute. After entering the correct password, press to proceed. If you enter the wrong password, the controller returns to the normal operation mode and you have to repeat this step.

2. "LANGUAG"



Default: ENG (English)  
Range: ENG (English)

Select the desired language.

3. "METRIC DISPLAY UNITS"



Default: ON  
Range: ON (metric units - °C, kg H<sub>2</sub>O/Hr), OFF (imperial units - °F, lbs H<sub>2</sub>O/Hr)

Select the desired measurement system.

4. "ECONO MODE"



Default: OFF (econo mode deactivated)  
Range: ON (econo mode activated), OFF (econo mode deactivated)

In Econo mode, the isolation valve will be closed when there is no demand.



*Important: For correct operation, set the econo mode feature to **OFF** (econo mode deactivated).*

5. "WORKING CAPACIT IN PCT"



Default: 100%  
Range: 10 to 100%  
Increment: 5%

This option enables you to adjust the maximum demand capacity of the full system capacity in %. This percentage is a factory setting. We recommend that you do not change this value without consulting Neptronic.

6. "SEPARAT TEMPER OFFSET"



Default: 0  
Range: -10 to 10°C [-18 to 18°F]  
Increment: 0.1°C [0.1°F]

Set the desired temperature reading.

7. "PCR TEMPER OFFSET"



Default: 0  
Range: -10 to 10°C [-18 to 18°F]  
Increment: 0.1°C [0.1°F]

Compare the displayed temperature of the sensor in the PCR tank with a known value from a thermometer or other temperature sensing device. To offset or calibrate the sensor, use the arrow buttons to set the desired temperature reading.

8. "JACKET TEMPER OFFSET"



Default: 0  
Range: -10 to 10°C [-18 to 18°F]  
Increment: 0.1°C [0.1°F]

This option appears only if the number of temperature switches is greater than 1. Adjust the temperature reading by using the offset.



9. "JACKET2 TEMPER OFFSET"



Default: 0  
Range: -10 to 10°C [-18 to 18°F]  
Increment: 0.1°C [0.1°F]

This option appears only if the number of temperature switches is greater than 2. Adjust the temperature reading by using the offset.

10. "JACKET3 TEMPER OFFSET"



Default: 0  
Range: -10 to 10°C [-18 to 18°F]  
Increment: 0.1°C [0.1°F]

This option appears only if the number of temperature switches is greater than 3. Adjust the temperature reading by using the offset.

11. "JACKET4 TEMPER OFFSET"



Default: 0  
Range: -10 to 10°C [-18 to 18°F]  
Increment: 0.1°C [0.1°F]

This option appears only if the number of temperature switches is greater than 4. Adjust the temperature reading by using the offset.

12. "CONTROL MODE"



Default: Extern  
Range: Intern, Extern, Net

Select the desired control mode from the available options.

- If Intern is selected: the humidifier is controlled by the SKDESC-J.
- If Extern is selected: the humidifier is controlled by an external signal.
- If Net is selected: the humidifier is controlled over the network. This option is available only on SKDESC-JB and SKDESC-JD models.

If you selected Intern or Net, go to Step 14 "NETWORK ROOM HUMIDTY".

13. "DEMAND SIGNAL RANGE"



Default: 2-10 Vdc  
Range: 0-10 Vdc, 2-10 Vdc

Select the desired relative humidity sensor signal.

14. "NETWORK ROOM HUMIDTY"



Default: OFF  
Range: OFF, ON

This option is only available on BACnet or Modbus models (SKDESC-JB or SKDESC-JD). Select **ON** if you want to control the humidity over the network.

If you selected ON, go to Step 17 "EXTERNAL HUMIDITY SETPOINT".

If you selected Intern at Step 0

"CONTROL MODE", go to Step 16 "ROOM HUMIDTY SIGNAL RANGE".

15. "ROOM HUMIDTY OFFSET IN PCT"



Default: 0% RH  
Range: -10 to 10% RH  
Increment: 0.1% RH

Adjust the room relative humidity reading by using the offset.



16. "ROOM HUMIDITY SIGNAL RANGE"



Default: 2-10 Vdc  
Range: 0-10 Vdc, 2-10 Vdc

Select the desired signal range from the available options.

If you selected Extern at Step 0

"Control Mode", go to Step 23 "High limit sensor".

17. "EXTERNA HUMIDTY SETPNT"



Default: OFF  
Range: OFF, ON

Select ON if you want to use an external setpoint for humidity.

If you selected OFF, go to Step 19 "interna humidty setpnt in pct".

18. "SETPNT SIGNAL RANGE"



Default: 2-10 Vdc  
Range: 0-10 Vdc, 2-10 Vdc

Select the desired relative humidity sensor signal. Go to Step 20 "control dead band in pct".

19. "INTERNA HUMIDTY SETPNT IN PCT"



Default: 40% RH  
Range: 10% to 90% RH  
Increment: 1% RH

Set the desired humidity setpoint in % RH.

20. "CONTROL DEAD BAND IN PCT"



Default: 2.0% RH  
Range: 0% to 5% RH  
Increment: 0.1% RH

Set the desired control dead band.

21. "CONTROL PROP RAMP IN PCT"



Default: 5.0%  
Range: 1% to 10%  
Increment: 0.1%

Set the desired control proportional ramp.

22. "CONTROL INTEGRA RAMP IN PCT"



Default: 5.0%  
Range: 1% to 10%  
Increment: 0.1%

Set the desired control integral ramp.

23. "HIGH LIMIT SENSOR"



Default: Digital (On/Off)  
Range: Disable, Analog, Digital (On/Off), Network

Select the desired type of high limit sensor from the available options. The Network option is available only on BACnet or Modbus models (SKDESC-JB or SKDESC-JD).

If you selected Digital, go to Step 28 "High limit max demand in pct".

If you selected Disable, go to Step 29 "END OF SEASON DELAY IN HR".



24. "HIGH LIMIT SETPOINT IN PCT"



Default: 80% RH  
Range: 10% to 90% RH  
Increment: 1% RH

Set the high limit relative humidity setpoint.

25. "HIGH LIMIT PROP RAMP IN PCT"



Default: 10.0 %  
Range: 0% to 20%  
Increment: 0.1%

Set the desired high limit proportional ramp.

If you selected Network at Step 23 "HIGH LIMIT SENSOR", go to Step 28 "High limit max demand in pct".

26. "HIGH LIMIT HUMIDTY OFFSET IN PCT"



Default: 0% RH  
Range: -10% RH to 10% RH  
Increment: 0.1% RH

Adjust the relative humidity reading of the room.

27. "HIGH LIMIT SIGNAL RANGE"



Default: 2-10 Vdc  
Range: 0-10 Vdc, 2-10 Vdc

Select the high limit signal range.

28. "HIGH LIMIT MAX DEMAND IN PCT"



Default: No default (information display only)

Displays the actual reading of the high limit sensor.

29. "END OF SEASON DELAY IN HR"



Default: 100 hours  
Range: 100 to 250 hours  
Increment: 5 hours

This option does not appear if you have selected **econo mode** at Step 4 "ECONO MODE". Indicates that the isolation valve will be turned off after 100 hours if there is no demand.

30. "SERVICE DELAY IN HR"



Default: 5000 hours  
Range: 1000 to 5000 hours  
Increment: 500 hours

Set the number of hours running at 100% capacity before servicing is due.

31. "SERVICE RUNTIME IN HR"



Default: No default (information display only)

Displays the running time in hours at 100% capacity since the last service has been performed. To reset this value to 0 and reset any associated alarms, press the edit (✖) button and then press and hold both △ and ▽ arrow keys.

32. "RUNS WHILE SERVICE ALARM"



Default: ACt (active)  
Range: INACt (Inactive), ACt (active)

Select **ACt** to enable the system to run even when the servicing is due.





33. "TOTAL RUNTIME IN HR"



Default: No default (information display only)

Displays the running time in hours at 100% capacity.

34. "PCR FALLBACK"



Default: Off  
Range: Off, On

This option determines operation of the PCR system when there is a water level or temperature sensor failure. When OFF, the PCR system stops functioning until the sensor issue is corrected. When ON, the PCR continues to function based on pre-determined internal timers in order to perform functions such as draining and filling.

35. "AUTO BAUD RATE"



Default: ON  
Range: ON, OFF

This option is available only on BACnet or Modbus models (SKDESC-JB or SKDESC-JD). Enable or disable Auto Baud Rate detection. When enabled, the controller automatically configures its baud rate by detecting the network speed upon connection to the network. When disabled, you must manually select the baud rate. (go to Step 36, "baud rate")

36. "BAUD RATE"



Default: No default (information display only)  
Range:  
BACnet 9.6k, 19.2k, 38.4k, 76.8k  
Modbus 9.6k, 19.2k, 38.4k, 57.6k

This option is available only on BACnet or Modbus models (SKDESC-JB or SKDESC-JD). If you selected ON at the previous step, the controller automatically detects and displays the baud rate. If you selected OFF at the previous step, select the baud rate value from the available options.

37. "NETWORK ADDRESS"



BACnet  
Default: 0  
Range: 0 to 254  
  
Modbus  
Default: 1  
Range: 1 to 246

This option is available only on BACnet or Modbus models (SKDESC-JB or SKDESC-JD). Select the desired address.

38. "ADJUST DEVICE INSTANCE"



Default: 0153001  
Range: No, Yes

To change the device instance, select Yes. If you select No, the device instance will be modified automatically according to the MAC address.

39. "NETWORK PARITY"



Default: None  
Range: None, Odd, Even

This option is available only on Modbus model (SKDESC-JD). Select the desired parity control from the available options.



40. "NETWORK STOP BITS"



Default: 1  
Range: 1,2

This option is available only on Modbus model (SKDESC-JD). Select the desired network stop bits.

41. "NETWORK FALLBACK TIMEOUT"



Default: 0 sec  
Range: 0 to 900 sec  
Increment: 1 sec

This option appears if you've set one of the inputs to **Net** at Step 0 "CONTROL MODE". Set the desired network fallback timeout.

42. "NETWORK FALLBACK SETPOINT"



Default: 0.0%  
Range: 0% to 100%  
Increment: 0.1%

This option appears if you've set one of the inputs to **Net at Step 0** "CONTROL MODE". Set the desired network fallback setpoint.

43. "NETWORK FALLBACK COUNTER"



Default: 0 sec  
Range: 0 to 900 sec  
Increment: 1 sec

This option appears if you've set one of the inputs to **Net at Step 0** "CONTROL MODE". **Set the desired network fallback counter.**

44. "CONTROL OUTPUT SIGNAL IN MV"



Default: No default (information display only)

Displays the control valve output in mV.

45. "PCR SUPPLY SIGNAL IN MV"



Default: No default (information display only)

Displays the PCR steam supply valve output in mV.

46. "ISOLAT VALVE OUTPUT STATE"



Default: No default (information display only)  
Range: INACt (closed), ACt (open)

Displays whether the isolating valve is open or closed.

47. "PCR RELIEF VALVE OUTPUT STATE"



Default: No default (information display only)

Displays whether the PCR relief valve is open or closed.

48. "ALARM RELAY OUTPUT STATE"



Default: No default (information display only)  
Range: INACt (closed), ACt (open)

Displays whether the alarm relay is open or closed.



49. "STEAM ON OUTPUT RELAY OUTPUT STATE"



Default: No default (information display only)  
Range: INACT (closed), ACT (open)

Displays whether the steam output relay is open or closed.

50. "SEPARAT TEMPER INPUT SIGNAL IN MV"



Default: No default (information display only)

Displays the separator temperature sensor reading in mV.

51. "JACKET1 TEMPER INPUT SIGNAL IN MV"



Default: No default (information display only)

This option appears only if the number of temperature switches is greater than 1. Displays the jacket temperature sensor reading in mV.

52. "JACKET2 TEMPER INPUT SIGNAL IN MV"



Default: No default (information display only)

This option appears only if the number of temperature switches is greater than 2. Displays the jacket temperature sensor reading in mV.

53. "JACKET3 TEMPER INPUT SIGNAL IN MV"



Default: No default (information display only)

This option appears only if the number of temperature switches is greater than 3. Displays the jacket temperature sensor reading in mV.

54. "JACKET4 TEMPER INPUT SIGNAL IN MV"



Default: No default (information display only)

This option appears only if the number of temperature switches is greater than 4. Displays the jacket temperature sensor reading in mV.

55. "DEMAND INPUT SIGNAL IN MV"



Default: No default (information display only)

This option appears only if you've selected **Extern** at Step 0 "CONTROL MODE". Displays the reading of demand in mV.

56. "ROOM HUMIDITY INPUT SIGNAL IN MV"



Default: No default (information display only)

This option does not appear if you've selected **OFF** at Step 14 "NETWORK ROOM HUMIDITY". Displays the relative humidity reading of the room in mV.



57. "SETPNT INPUT SIGNAL IN MV"



Default: No default (information display only)

This option appears only if you've selected **ON** at Step 17 "EXTERNA HUMIDITY SETPNT". Displays the setpoint reading in mV.

58. "HIGH LIMIT INPUT SIGNAL IN MV"



Default: No default (information display only)

This option appears only if you've selected **Analog** at Step 23 "HIGH LIMIT SENSOR". Displays the high limit sensor reading in mV.

59. "WATER LEVEL INPUT SIGNAL IN MV"



Default: No default (information display only)

Displays the reading in mV of the water level sensor inside the PCR tank.

60. "EXTERN DEMAND INPUT STATE"



Default: No default (information display only)  
Range: INACt (closed), ACt (open)

This option appears only if you've selected **Extern** at Step 0 "CONTROL MODE". Displays if the demand is open or closed.

61. "AIR FLOW INPUT STATE"



Default: No default (information display only)  
Range: INACt (closed), ACt (open)

Displays if the air flow switch is open or closed.

62. "HIGH LIMIT SWITCH INPUT STATE"



Default: No default (information display only)  
Range: INACt (closed), ACt (open)

This option appears only if you've selected **Digital** at Step 23 "HIGH LIMIT SENSOR". Displays if the high limit switch is open or closed.

63. "INTRLCK INPUT STATE"



Default: No default (information display only)  
Range: INACt (closed), ACt (open)

Displays if the interlock is open or closed.

64. "MICRO TEMPER"



Default: No default (information display only)

Displays whether the microcontroller temperature is in °C or °F mode.

65. "PCB TEMPER"





Default: No default (information display only)

Displays whether the PCB temperature is in °C or °F mode.



## Alarms and Notifications

The following is a list of alarms and notifications displayed by the Steam Controller under different conditions. When each one of these occurs, the controller performs certain actions as described in the table. The alarm symbol,  is displayed along with the all the alarms and notifications.

Display	Description
<i>NO AIR FLOW ALARM</i>	Indicates that the air flow sensor is not detected. <ul style="list-style-type: none"> <li>- control valve is closed</li> <li>- isolating valve is closed</li> </ul>
<i>HIGH LIMIT CUTOFF ALARM</i>	Indicates that the duct humidity has exceeded the high limit level. <ul style="list-style-type: none"> <li>- control valve is closed</li> <li>- isolating valve is closed</li> <li>- alarm relay is activated</li> </ul>
<i>SERVICE WARNING ALARM</i>	Indicates that the servicing is due in less than 100 hours.  Service the unit and reset the unit at Step 31 " <i>SERVICE RUN TIME IN HR</i> " by pressing the arrow keys  ,  for three seconds.
<i>SERVICE UNIT ALARM</i>	Indicates that the service is due. This alarm won't stop the system from running unless you've set the option to inact at Step 32 "runs while service alarm". <ul style="list-style-type: none"> <li>- control valve is closed</li> <li>- isolating valve is closed</li> <li>- alarm relay is activated</li> </ul>
<i>INTERLOCK ALARM</i>	Indicates that the inter lock is activated. <ul style="list-style-type: none"> <li>- control valve is closed</li> <li>- isolating valve is closed</li> <li>- alarm relay is activated</li> </ul>
<i>FLOODED SEPARATE STEAM TRAP FAILURE</i>	Indicates that either the separator steam trap is flooded or the temperature is too low. <ul style="list-style-type: none"> <li>- control valve is closed</li> <li>- alarm relay is activated</li> </ul>
<i>FLOODED JACKET1 STEAM TRAP FAILURE</i>	Indicates that either the jacket steam trap is flooded or the temperature is too low. <ul style="list-style-type: none"> <li>- control valve is closed</li> <li>- alarm relay is activated</li> </ul>
<i>FLOODED JACKET2 STEAM TRAP FAILURE</i>	Indicates that either the jacket 2 steam trap is flooded or the temperature is too low. <ul style="list-style-type: none"> <li>- control valve is closed</li> <li>- alarm relay is activated</li> </ul>
<i>FLOODED JACKET3 STEAM TRAP FAILURE</i>	Indicates that either the jacket 3 steam trap is flooded or the temperature is too low. <ul style="list-style-type: none"> <li>- control valve is closed</li> <li>- alarm relay is activated</li> </ul>
<i>FLOODED JACKET4 STEAM TRAP FAILURE</i>	Indicates that either the jacket 4 steam trap is flooded or the temperature is too low. <ul style="list-style-type: none"> <li>- control valve is closed</li> <li>- alarm relay is activated</li> </ul>
<i>SEPARAT TEMPER SENSOR FAILURE</i>	Indicates that the separator sensor is defective. <ul style="list-style-type: none"> <li>- control valve is closed</li> <li>- isolating valve is closed</li> <li>- alarm relay is activated</li> </ul>
<i>PCR TEMPER SENSOR FAILURE</i>	Indicates that the PCR tank's temperature sensor is defective. <ul style="list-style-type: none"> <li>- control valve is closed</li> <li>- isolating valve is closed</li> <li>- alarm relay is activated</li> </ul>



<b>Display</b>	<b>Description</b>
<i>JACKET1 TEMPER SENSOR FAILURE</i>	Indicates that the jacket sensor is defective. <ul style="list-style-type: none"><li>- control valve is closed</li><li>- isolating valve is closed</li></ul> alarm relay is activated
<i>JACKET2 TEMPER SENSOR FAILURE</i>	Indicates that the jacket 2 sensor is defective. <ul style="list-style-type: none"><li>- control valve is closed</li><li>- isolating valve is closed</li></ul> alarm relay is activated
<i>JACKET3 TEMPER SENSOR FAILURE</i>	Indicates that the jacket 3 sensor is defective. <ul style="list-style-type: none"><li>- control valve is closed</li><li>- isolating valve is closed</li></ul> alarm relay is activated
<i>JACKET4 TEMPER SENSOR FAILURE</i>	Indicates that the jacket 4 sensor is defective. <ul style="list-style-type: none"><li>- control valve is closed</li><li>- isolating valve is closed</li></ul> alarm relay is activated
<i>ROOM HUMIDITY SENSOR FAILURE</i>	Indicates that the room humidity sensor has failed. <ul style="list-style-type: none"><li>- control valve is closed</li><li>- isolating valve is closed</li></ul> alarm relay is activated
<i>HIGH LIMIT HUMIDITY SENSOR FAILURE</i>	Indicates that the high limit humidity sensor has failed. <ul style="list-style-type: none"><li>- control valve is closed</li><li>- isolating valve is closed</li></ul> alarm relay is activated
<i>PCR WATER LEVEL SENSOR FAILURE</i>	Indicates that the PCR tank's water level sensor has failed. <ul style="list-style-type: none"><li>- control valve is closed</li><li>- isolating valve is closed</li><li>- alarm relay is activated</li></ul>



## Operating Menu Display

### Power Up

Upon power up, the LCD illuminates and all segments appear for 2 seconds. The thermostat then displays its serial number, model, and revision for 2 seconds. In the Operation Mode, the information is displayed automatically in a sequence. If you wish to scroll the information quickly, use the  $\triangle$ ,  $\nabla$  arrow keys.

### Humidity Levels

The following humidity levels are displayed:

- *HUMIDITYSETPNTINPCT* - Humidity setpoint in % RH
- *ROOMHUMIDTYINPCT* - Room humidity reading in % RH
- *HIGHLIMITHUMIDTYINPCT* - Duct sensor reading in % RH

### Control Parameters

The following control parameters are displayed:

- *CONTROLDEMANDINPCT* - Current demand of the total system capacity measured in %
- *CONTROLOUTPUTINPCT* - Current output of the total system capacity measured in %
- *CONTROLDEMAND* - Current demand measured in kg/hr or lbs/hr
- *CONTROLOUTPUT* - Current output measured in kg/hr or lbs/hr

### Temperature Levels

The following temperature level is displayed:

- *SEPARATTEMPER* - Separator temperature measured in °C or °F
- *PCRTEMPER* - PCR tank temperature measured in °C or °F





## Initial Verification

---



Any installation work must be carried out by suitably qualified personnel.

## Installation

- Ensure that the humidifier is installed properly according to the installation manual.
- Check that steam distributors are properly installed into the ventilation duct.
- Ensure that there is no leakage on the Pressurized Condensate Return System piping.

## Electrical

- Confirm that 24Vac is present between tab 1&4 of terminal block TB5 on the SKDESC Steam Controller.

## Drain if Needed (Mini Rack or Multi-Tube)

- If there is a steam trap on the header, confirm that the drain piping is properly connected with a pitch of at least ¼" (6.5mm) per foot (300mm). There is no header on the Jacketed Single Tube configuration and therefore there is no steam trap on the header.

## Steam Supply

- Ensure that the steam supply is on.
- Ensure that there is no leakage on the steam piping when the steam supply is on.

## Controls

- Ensure that a high limit duct humidistat is installed, properly connected to the SKDESC and the setpoint is properly adjusted.
- Verify that the room humidistat or returned air duct humidistat is installed, properly connected to the SKDESC, and the setpoint is properly adjusted.
- Turn on the power at the disconnect switch.
- Confirm the control setup of the humidifier. The humidifier is factory set with EXTERNAL control setup, which means that the humidity demand is controlled by the room or duct humidistat.
- Ensure that the type of signal (0-10 Vdc, 2-10 Vdc or 4-20 mA) of the humidistat corresponds to the type set in the humidifier control set-up.



# Start-Up Procedure

---

## Start-up

Proceed to start-up the humidifier as follows:

- Make sure that the steam is supplied to the Pressurized Condensate Return System.
- Switch on the SKDESC-J.
- Make sure that there is no alarm. If the A6 alarm stays on, it means that the steam does not reach the separator or there is a problem with evacuating the condensate from the separator steam trap.

Wait for a call for humidity or create it by setting the SKDESC-J

- "CONTROL MODE" to Internal (step #0), and the "EXTERNA HUMIDITY SETPNT" to OFF (step #17). Then, adjust the setpoint to a higher value than the room humidity reading (operation mode B).
- Once the temperature is high enough, the control valve will open slowly.
- The start-up is complete and the humidifier is now functional.

## Safety Test

- Check for steam or condensate leakage while the humidifier is in operation.
- Check the location of the airflow switch in the system and its operation by stopping the fan or by disconnecting the air pressure connection. With no air movement in the duct, SKDESC-J will automatically stop the humidifier by closing the control valve.

## Reset the Setpoint and Control Mode

- If the humidity setpoint is controlled by the SKDESC-J, reset the setpoint to the desired relative humidity % (set #20) as suits the room.
- If the humidity setpoint is controlled by another device than the SKDESC-J (typically by the BMS), set the internal control signal to OFF.

## End

- The humidifier is ready for normal operation.



**neptronic®**

400 Lebeau blvd, Montreal, Qc, H4N 1R6, Canada

[www.neptronic.com](http://www.neptronic.com)

Toll free in North America: 1-800-361-2308

Tel.: (514) 333-1433

Fax: (514) 333-3163

Customer service fax: (514) 333-1091

Monday to Friday: 8:00am to 5:00pm (Eastern time)